

## 10Gb/s SFP+ 1310nm 10km Transceiver

### TS3111L-EN Product Specification

#### FEATURES

- Typical data rate 10.3125Gbps
- 1310nm DFB Laser and PIN photo detector
- Duplex LC receptacle
- Single +3.3V power supply
- Hot-pluggable
- International Class1 laser safety certified
- Operating temperature range: -20 ~ +85 °C
- RoHS Compliant
- Support Digital Diagnostic Monitoring interface
- Max reach 10km over SMF

#### APPLICATIONS

- 10GBASE-LR/LW
- 10G Fiber Channel
- SFP+ MSA (SFF-8472)
- IEEE802.3ae

#### ORDERING INFORMATION

Part Number	Form Factor	Data Rate	Media	Distance (km)	Wavelength (nm)	Temperature (°C)
TS3111L-EN	SFP+	10.3Gbps	SMF	10	1310	-20~85

## ABSOLUTE MAXIMUM RATINGS

Exceeding the limits below may damage the transceiver permanently.

Parameter	Symbol	Min	Typ	Max	Unit.	Note
Storage Temperature	TSTG	-40	-	85	°C	
Operating Relative Humidity	RH	5	-	95	%	
Supply Voltage	VCC	-0.5	-	4	V	

## RECOMMENDED OPERATING CONDITIONS

Parameter	Symbol	Min	Typ	Max	Unit.	Note
Operating Case Temperature	Tc	-20	-	85	°C	
Supply Voltage	VCC3	3.13	3.3	3.47	V	
Supply Current	ICC3	-	-	300	mA	+3.3V Supply
Data Rate	DR	-	10.3125	-	Gbps	

## ELECTRICAL and OPTICAL CHARACTERISTICS

Parameter	Symbol	Min	Typ	Max	Unit.	Note
<b>Transmitter@10.3125Gbps</b>						
Tx Differential Input Amplitude	Vin p-p	180	-	700	mV	
Input Differential Impedance	Zin	80	100	120	Ω	
Output Optical Power	PO	-8.2	-	0.5	dBm	
Extinction Ratio	ER	3.5	-	-	dB	
Center Wavelength Range	λc	1260	1310	1355	nm	
Spectrum Width(-20dB)	Δλ	-	-	1	nm	
Optical Return Loss Tolerance	RL	12	-	-	dB	
Output Optical Eye	Compliant with G.957					
Tx Disable Voltage	VOH	2	-	VCC	V	LVTTTL
	VOL	0	-	0.4	V	LVTTTL
Optical Power at Tx Disable	Ptxdis	-	-	-30	dBm	
<b>Receiver@10.3125Gbps</b>						
Rx Differential Output Amplitude	Vout p-p	300	-	850	mV	
Receiver Optical Wavelength	λc	1260	-	1355	nm	
Receiver Sensitivity	Sen	-	-	-15	dBm	Note 1
Receiver Overload	OL	0.5	-	-	dBm	
LOS Voltage	Normal	2	-	Vcc	V	LVTTTL
	Fault	0	-	0.4	V	LVTTTL

Parameter	Symbol	Min	Typ	Max	Unit.	Note
LOS Assert Level	LOSA	-30	-	-	dBm	
LOS De-Assert Level	LOSD	-	-	-17	dBm	
LOS Hysteresis	LOSH	0.5		6	dB	

**Notes:**

1.Measured with 2<sup>31</sup>-1 NRZ Pattern. BER≤1E-12@10Gpbs, ER=3.5dB

**Digital Diagnostic Functions**

Parameter	Symbol	Min.	Max.	Unit	Repeatability	Notes
Temperature	DDMI_Temp	-3	3	°C	± 1°C	1LSB=1/256°C
Supply Voltage	DDMI_VCC	-3%	3%	V	± 1 %	1LSB=0.1mV
Bias Current	DDMI_Ibias	-10%	10%	mA	± 5 %	1LSB=2uA
TX Optical Power	DDMI_TX	-3	+3	dB	± 0.5 dB	1LSB=0.1uW
RX Optical Power	DDMI_RX	-3	+3	dB	± 1.5 dB	1LSB=0.1uW

**PIN DIAGRAM**

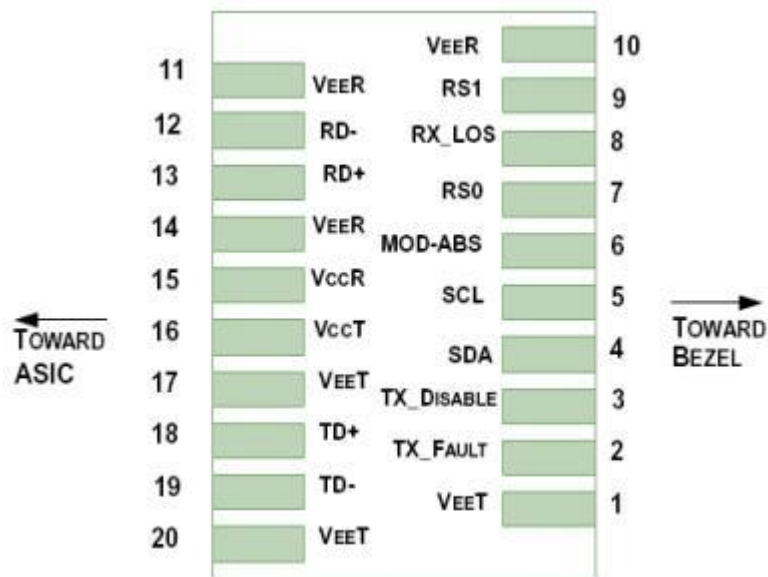

## PIN DESCRIPTIONS

Pin	Symbol	Description	Notes
1	VEET	Module Transmitter Ground	1
2	TX_FAULT	Module Transmitter Fault	2
3	TX_DISABLE	Transmitter Disable; Turns off transmitter laser output	3
4	SDA	2-Wire Serial Interface Data Line (MOD-DEF2)	
5	SCL	2-Wire Serial Interface Clock (MOD-DEF1)	
6	MOD_ABS	Module Absent, connected to VEET or VEER in the module	2
7	RS0	Rate Select 0, NOT implement	4
8	RX_LOS	Receiver Loss of Signal Indication (in FC designated as RX_LOS, in SONET designated as LOS, and in Ethernet designated as NOT Signal Detect)	2
9	RS1	Rate Select 1, NOT implement	4
10	VEER	Module Receiver Ground	1
11	VEER	Module Receiver Ground	1
12	RD-	Receiver Inverted Data Output	
13	RD+	Receiver Non-Inverted Data Output	
14	VEER	Module Receiver Ground	1
15	VCCR	Module Receiver 3.3 V Supply	
16	VCCT	Module Transmitter 3.3 V Supply	
17	VEET	Module Transmitter Ground	1
18	TD+	Transmitter Non-Inverted Data Input	
19	TD-	Transmitter Inverted Data Input	
20	VEET	Module Transmitter Ground	1

### Notes:

- 1.The module ground pins are isolated from the module case.
- 2.The pins shall be pulled up with 4.7K- 10Kohms to a voltage between 3.14V and 3.46V on host board.
- 3.The pin is pulled up to VCCT with a 4.7K- 10KΩ resistor in the module.
- 4.The pins are pulled low to VEET with a >30kΩ resistor in the module.

### MECHANICAL SPECIFICATION

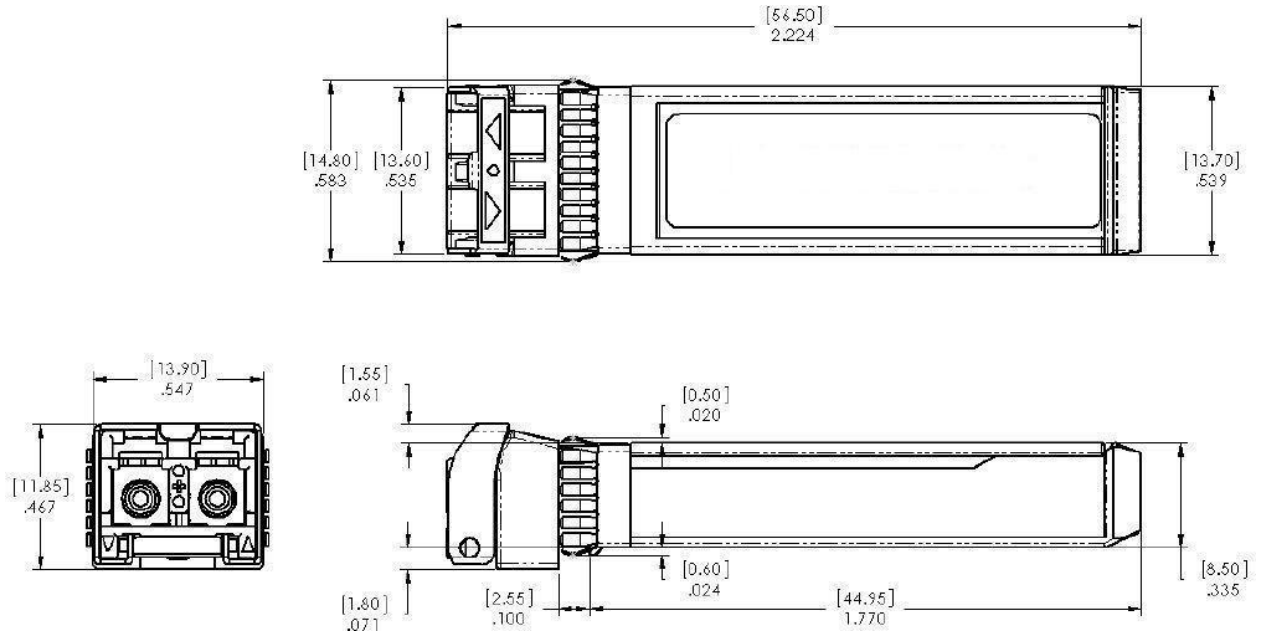

### LABEL DIAGRAM



**TS311L-EN**

SFP+ 10G Duplex 1310nm 10km LC

Class 1 Laser  
MADE IN CHINA

S/N: ??????????



X.XX.XX.XXX